

DAB WASTE WATER PUMP RANGE

HiFLOPUMPS
Service . Expertise . Quality

DAB
WATER • TECHNOLOGY

FEKA VS750MA & VS1200MA

The DAB Feka VS pumps are an all Stainless steel submersible centrifugal pump fitted with a cast stainless steel vortex impeller. The DAB Feka VS pumps are suitable for pumping sewage, waste water and storm water with solids up to 50 mm in diameter. This makes them ideal for domestic & light commercial sewage applications.

DAB Feka pumps are fitted with double mechanical seal in an oil bath. The motors are continuously rated for temperatures up to 35 Deg. C. The pumps are fully serviceable and along with the robust design and construction, provides great value.

- The pumps are supplied with an integrated float switch for automatic operation.
- Power cable: 10 metre H07RN-F, with plug.
- Max starts/hour: 20

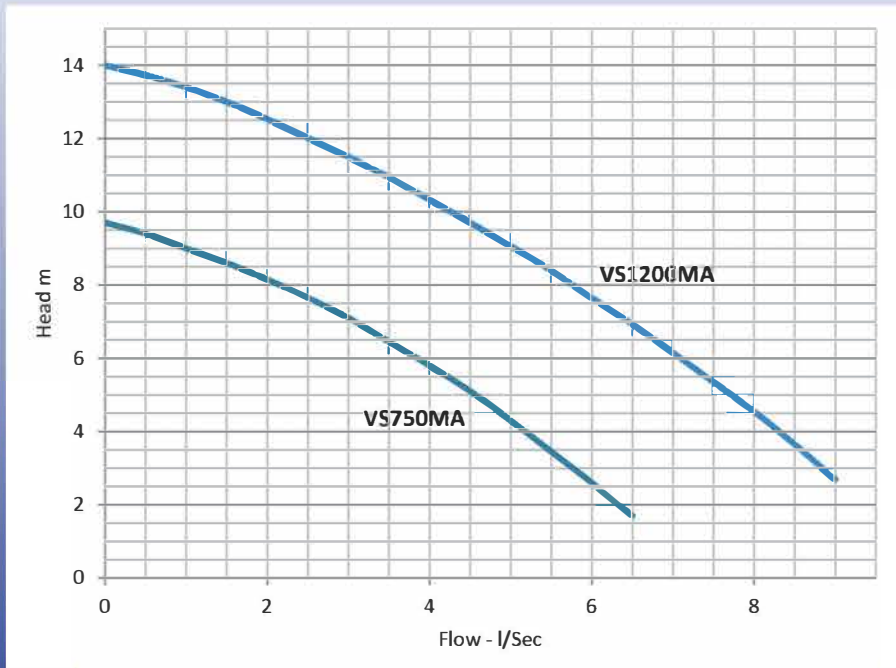

Model	Type	Solids Size	Auto/Manual	Motor Size	Voltage	FLC - Amps	Discharge	Height	Diameter	Weight
VS750MA	Sewage Pump 50mm Solids - Vortex Impeller	50mm	Auto	0.75kW	1 x 240	5.13	50mm	492mm	203mm	17.5kg
VS1200MA	Sewage Pump 50mm Solids - Vortex Impeller	50mm	Auto	1.2kW	1 x 240	8.63	50mm	537mm	203mm	20.8kg

DAB WASTE WATER PUMP RANGE

HiFLOPUMPS
Service . Expertise . Quality

DAB
WATER • TECHNOLOGY

DAB Feka Box FX 200L

The DAB Feka Box FX 200L is a 200 litre heavy duty polypropelene Pump station designed for sewerage waste water, rainwater and grey water pumping applications. They are designed for use with the Feka VS pumps. However, they can be used with grinder pumps for high head applications.

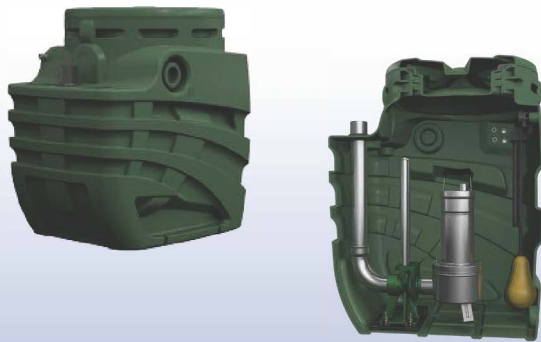

Capacity [l]	200
Connections	2-DN110, DN50 vertical inlets 1-DN110, DN50 horiz. inlet 1-2" vertical pump-out 1-DN40 emergency pump-out 1-DN 50 vent
Overall Dimensions [mm]	D: 750 x L: 600 x H: 779
Complete with	2" and 1" ¼ lifting device with anti-rotation bracket
Recommended Pumps	FEKA VX 750-1200MA
Operating Range	From 1 to 24 m³/h with head up to 15 mt

The Feka Box FX 200L pump stations are designed for surface mounting. Access to the pump is via the screw off tank lid that is sealed with a heavy duty rubber gasket. The lid can be locked in place to prevent tampering. We recommend the use of a CP1 control panel to provide protection for the pump motor and a high level alarm/pump fault alarm indication.

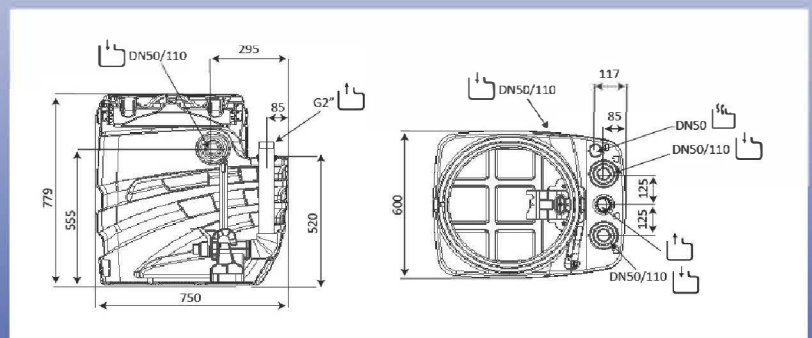

No matter the application Hi Flo Pumps can provide the solution you need, feel free to visit our Auckland or Rotorua branches to have a chat about the Showfou Range, alternatively flick us a call or an email.

Hi FLO Auckland
3 Fairfax Avenue, Penrose, Auckland
09 579 6375
Sales@hiflopumps.co.nz

Hi FLO Rotorua
72 Old Taupo Road, Mangakakahi, Rotorua
07 348 7516
Sales@hiflopumps.co.nz